



SC27G755D2

◎ POWER RATING

Engine Speed rpm	Type of Operation	Engine Power	
		kW	Ps
1500	Prime Power	505	687
	Standby Power	555	755

-. The engine performance is as per GB/T2820.

-. Ratings are based on GB/T1147.1.

---Prime power is available for an unlimited number of hours per year in a variable load application. The permissible average power output over 24 hours of operation shall not exceed 80% of the prime power rating.

---Standby power is available in the event of a utility power outage or under test conditions for up to 200 hours of operation per year.

The permissible average power output over 24 hours of operation shall not exceed 80% of the standby power rating.

◎ SPECIFICATIONS

- Engine Model SC27G755D2
- Engine Type V-type,4 strokes, water-cooled
Turbo charged
air-to-air intercooled
- Combustion type Direct injection
- Cylinder Type Wet liner
- Number of cylinders 12
- Bore × stroke 135(5.32) × 155(6.1) mm(in.)
- Displacement 26.6(1623) lit.(in3)
- Compression ratio 16 : 1
- Firing order 1-12-5-8-3-10-6-7-2-11-4-9
- Injection timing 11.5°BTDC
- Dry weight Approx. 2250kg (4960 lb)
- Dimension 1930×1686×1872mm
(L×W×H) (76×66.4×75.8 in.)
- Rotation Counter clockwise viewed from
Flywheel
- Fly wheel housing SAE NO.0
- Fly wheel SAE NO.18

◎ MECHANISM

- Type Over head valve
- Number of valve Intake 1, exhaust 1 per cylinder
- Valve lashes at cold Intake 0.325mm (0.0128 in.)
Exhaust 0.375mm (0.0148 in.)

◎ VALVE TIMING

- | | Opening | Close |
|-----------------|--------------|--------------|
| ○ Intake valve | 20 deg. BTDC | 48 deg. ABDC |
| ○ Exhaust valve | 48 deg. BBDC | 20 deg. ATDC |

◎ COOLING SYSTEM

- Cooling method Fresh water forced circulation
- Water capacity 48 liters (12.7 gal.)

◎ FUEL CONSUMPTION

- | ○ Power | lit/hr |
|---------|--------|
| 25% | 37.8 |
| 50% | 66.3 |
| 75% | 95.3 |
| 100% | 126.0 |
| 110% | 139.0 |

◎ FUEL SYSTEM

- Injection pump Yijie in-line “P” type
- Governor Electric type
- Feed pump Mechanical type
- Injection nozzle Multi hole type
- Opening pressure 240kg/cm2 (3414 psi)
- Fuel filter Full flow, cartridge type
- Used fuel Diesel fuel oil

◎ LUBRICATION SYSTEM

- Lub. Method Fully forced pressure feed type
- Oil pump Gear type driven by crankshaft
- Oil filter Full flow, cartridge type
- Oil pan capacity High level 65 liters (17.16 gal.)
Low level 55 liters (14.52 gal.)
- Angularity limit Front down 25 deg.
Front up 35 deg.
Side to side 35 deg.
- Lub. Oil Refer to Operation Manual

◎ ENGINEERING DATA

- Water flow 740 liters/min @1,500 rpm
- Heat rejection to coolant 68 kcal/sec @1,500 rpm

- (engine only)
- Pressure system Max. 0.5 kg/cm² (7.11 psi)
- Water pump Centrifugal type driven by belt
- Water pump Capacity 740 liters (195.36 gal./min at 1,500 rpm (engine)
- Thermostat Wax–pellet type
Opening temp. 77°C
Full open temp. 90°C
- Cooling fan Blower type,iron
1220 mm diameter, 6 blades

- Heat rejection to CAC 32 kcal/sec @1,500 rpm
- Air flow 36 m³/min @1,500 rpm
- Exhaust gas flow 91.8 m³/min @1,500 rpm
- Exhaust gas temp. 600 °C @1,500 rpm
- Max. permissible restrictions
Intake system 3 kPa initial
6 kPa final
Exhaust system 6 kPa max.
- Max. permissible altitude 2,000 m

◎ ELECTRICAL SYSTEM

- Charging generator 28V×55A
- Voltage regulator Built-in type IC regulator
- Starting motor 24V×11kW
- Battery Voltage 24V
- Battery Capacity 200 AH

◆ CONVERSION TABLE

- in. = mm × 0.0394
- PS = kW × 1.3596
- psi = kg/cm² × 14.2233
- in³ = lit. × 61.02
- hp = PS × 0.98635
- lb = kg × 2.20462
- lb/ft = N.m × 0.737
- U.S. gal = lit. × 0.264
- kW = 0.2388 kcal/s
- lb/PS.h = g/kW.h × 0.00162
- cfm = m³/min × 35.336

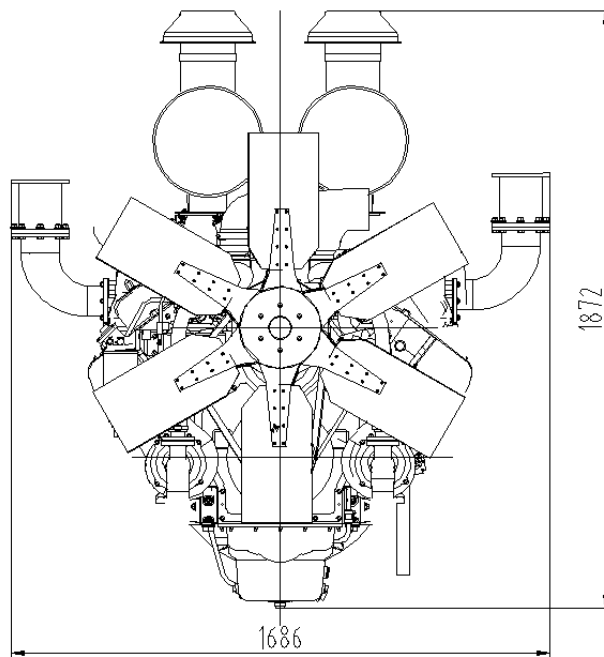
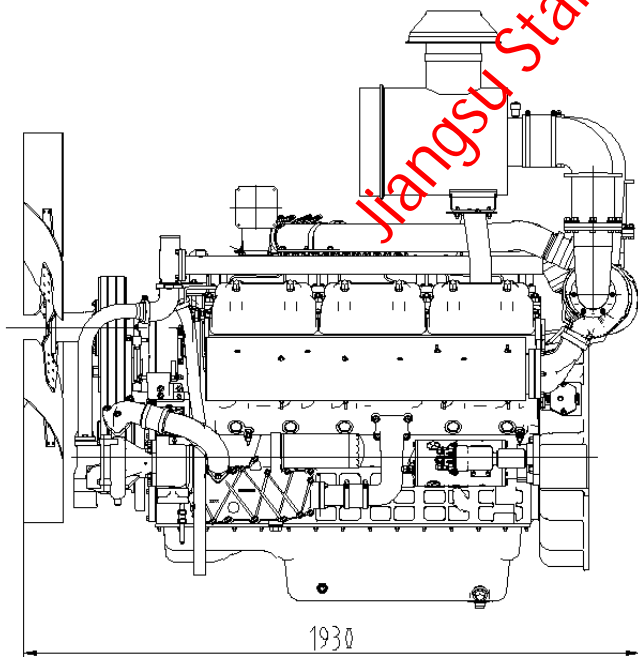

Jiangsu Starlight Electricity Equipment Co., Ltd - Diesel Generator Set Manufacturer

Adds: No.2 Xingguang Road, Guxi Industrial Park, Taixing, Jiangsu, China

E-mail: sales@dieselgeneratortech.com

Website: www.dieselgeneratortech.com

Tel: +86 134 8102 4441



WeChat